

Dahl

L100

Bubble-Tube Liquid Level System

Precision Transmission of Liquid Level in Open Tanks

The Dahl L100 Bubble-Tube Level System is a fully self-contained instrument, requiring only connections to air or gas supply, dip tube and electrical power source to provide precise level indication. Because only the stationary dip tube and the purge gas come in contact with the liquid, this system is ideal for applications involving hazardous locations or liquids which are highly corrosive, viscous, hot, (molten metal), explosive, slurry type or floodstuff. In addition, the electronic output from the L100 is compatible with almost all analog instrumentation, including local and remotely-located indicators, computers, data loggers, recorders and controllers.

Features

- **Totally Solid State**
- **High accuracy and Stability**
- **Four Times Rated F.S. Overpressure Safety Factor**
- **Visual Purge Rate Indication**
- **Blow-Down Capability**
- **Excellent for Hazardous, High-Temperature, Corrosive or Waste Water Level Measurement**
- **NEMA 4X Enclosures Available**

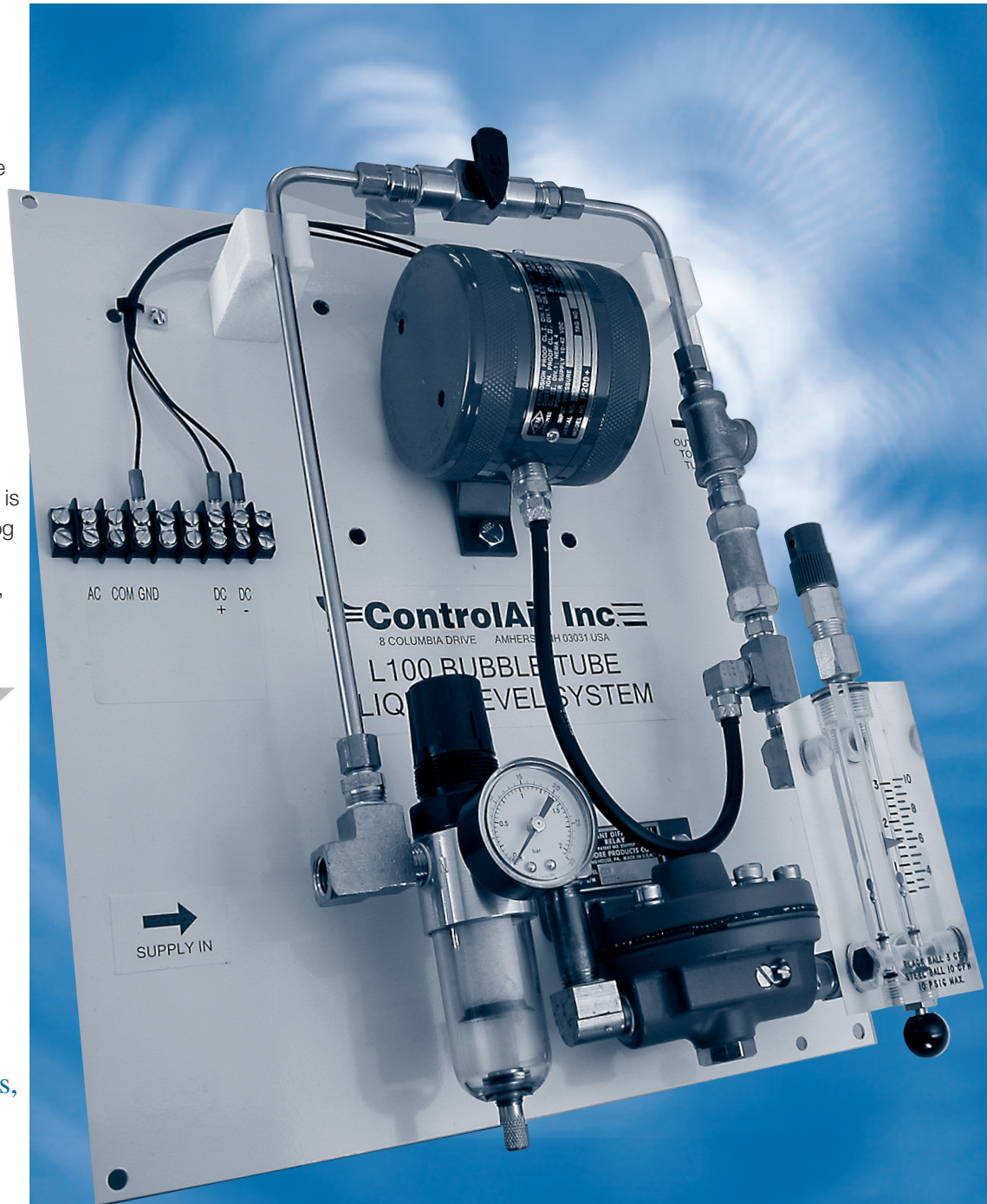

ControlAir Inc.



L100

Highly accurate and stable level indication-

The L100 Bubble-Tube Level System provides a variety of features which simplify the application of purge-tube techniques to liquid level measurement. Using the field-proven Dahl P200 P/I Transducer, this system is capable of superior accuracy and longevity. Over-pressure relief and back-flow check valves are used to protect the P/I transducer and are supplied as standard in every system along with a rotameter to read purge flow rates. Provision for manual blow-down of the bubble pipe by high pressure air is included to allow the user to clear any obstruction or media build-up from the bubble pipe.

Aside from the many standard features of the Dahl L100 Bubble-Tube Level System, there are numerous options which are listed in the specifications section. If your specific configuration is not listed, the Bubble-Tube System may be custom-configured to your requirements.

Principles of Operation

In the L100 Bubble-Tube Liquid Level System, the level in a vented tank is determined by measuring the pressure required to force gas into the liquid at a point beneath the surface. This system provides accurate level measurement without liquid entering the piping or the instrument.

A pressure regulator and constant-flow regulator combine to establish a consistent flow of clean air or gas to a bubble pipe immersed a fixed distance in the tank. The flow is regulated to a very low level, building up pressure in the bubble pipe until it just balances the fluid pressure at the end of the bubble pipe. Thereafter, pressure is kept at this value by escape of air bubbles through the liquid. Changes in the tank level cause the pressure in the bubble pipe to build or drop. The P200 pressure transducer is used to measure this pressure and send an electrical signal proportional to the level or volume of liquid.

The presence of the high-quality, industry-leading Dahl P/I transducer in the L100 Bubble-Tube Level System provides the user with an established and recognized electronic interface. Since the totally solid-state P200 transducer is typically capable of accuracies of 0.15% of span, the entire L100 System can be expected to maintain a 0.25% accuracy. The L100 may safely be used in indoor or outdoor hazardous areas due to the NEMA 4 protection and the FM/CSA intrinsically safe and explosion-proof design of the Dahl P200.

S P E C I F I C A T I O N S

Ranges	0-50 inches water to 0-115 feet water or equivalent, full scale
Gas Input	1.0 to 7.0 SCFH, regulated on-board to a pressure between 120% or 3 psi, whichever is greater, and 200% of full scale liquid head. Maximum blow-down pressure is 150 psi. Maximum on-board regulated pressure is 60 psi
Electrical Input	Using P200: 10-42 VDC
Electrical Output	P200: 2 wire, 4-20mA into 700Ω at 24 VDC or 2 wire, 10-50mA into 280Ω at 24 VDC
Accuracy	± 0.25% of span guaranteed; ±0.20% of span typical. Includes combined effects of linearity, hysteresis and repeatability errors.
Sensitivity	±0.02% of span guaranteed
Repeatability	±0.10% of span guaranteed; ±0.05% of span typical
Operating Temperature	30°F to 161°F
Thermal Sensitivity	Span: 0.007% of span per °F guaranteed Zero: 0.007% of span per °F guaranteed
RFI/EMI Effect	Meets or exceeds SAMA PMC 33.1, 1978, 2-abc: 0.1% of span at 10 volts/meter
Environmental	P/I is NEMA 4X and explosion proof, standard. Entire plate assembly fits in an optional NEMA 4X enclosure for further protection.
Available Options	NEMA 4X enclosure with or without digital readout, remote analog readout, auto purge

-excellent for hazardous or high-temperature liquids

A P P L I C A T I O N S

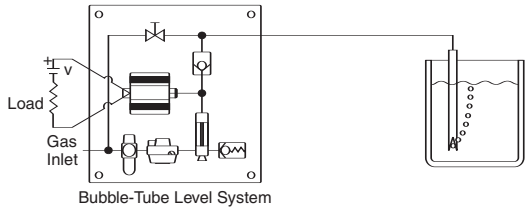

L100 BASIC SYSTEM

Standard bubble-tube configuration provides excellent accuracy and stability. Factory preset ranges available from 0-50" to 0-115'.

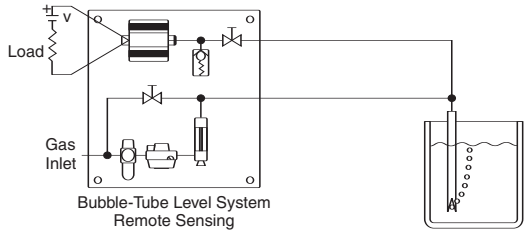

L100R REMOTE SENSING

This approach eliminates the small errors which can occur when operational changes cause a small change in purge flow. In this configuration, there is no flow in the measurement line as in the L100

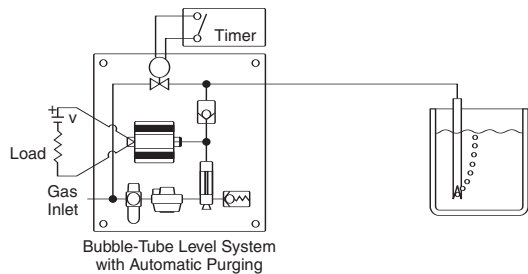

L100A AUTOMATIC BLOW DOWN

This arrangement allows for periodic bubble-tube blow-down to clear the tube on an automatic basis with no operator interface. Upon request, the L100 can be configured at the factory for automatic blow-down or remote sensing.

D I M E N S I O N S

BASIC L100

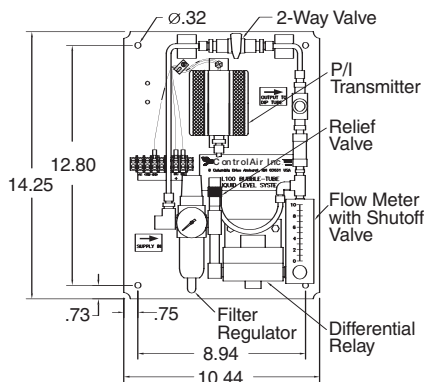

L100 ARE

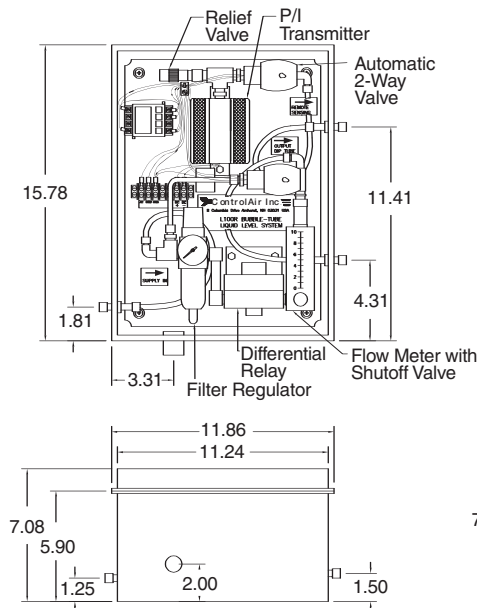

L100 AEW

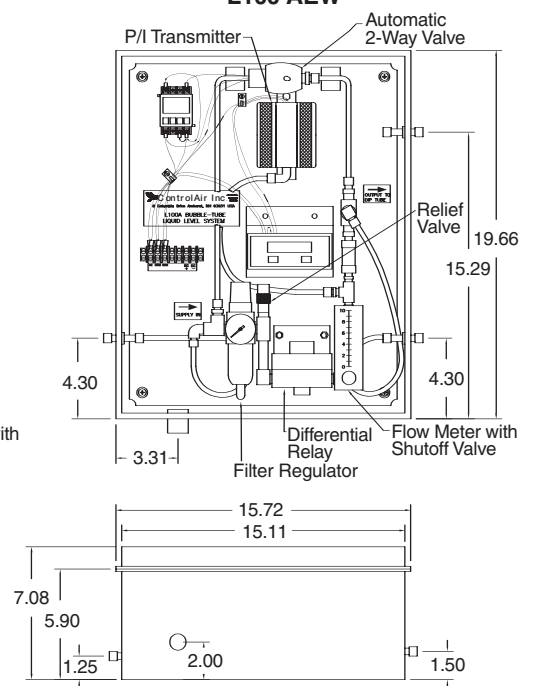

The following ordering codes are sufficient to specify a complete bubble-tube system with the exception of the P/I transducer. The P/I transducer must be ordered separately. Please refer to ControlAir's specifications for the Dahl P200 P/I Transducer.

ASSEMBLIES

Ordering Code	Description
L100	Basic bubble-tube system
L100R	Basic system with remote pressure sensing
L100A	Basic system with automatic blow-down
L100AR	Basic system with remote pressure sensing and automatic blow-down

For a NEMA 4X Enclosure, add suffix E to end of part number.
For a 4X enclosure with window and digital readout, add suffix EW to end of part number.

Example: L100RE.

RANGES

Ordering Code	Description
L11	0-50" WC to 0-166" WC, specify
L12	0-167" WC to 0-498" WC, specify
L13	0-499" WC to 0-830" WC, specify
L14	0-831" WC to 0-1384" WC, specify

OPTIONS

Ordering Code	Description
L22	Digital readout, scaled for range*

*Analog readout available as P200 option P27

When ordering, it is necessary to specify the model number, range and all options in the following manner:

L100REW + **L12**
System with remote sensing in NEMA 4X enclosure with window and digital readout
Range, specify 0-322" WC

The P/I transducer must be ordered separately. Please refer to ControlAir's specifications for the ControlAir Dahl P200 P/I Transducer.

When ordering, please indicate the specific gravity of the liquid being measured if it is different from that of water.

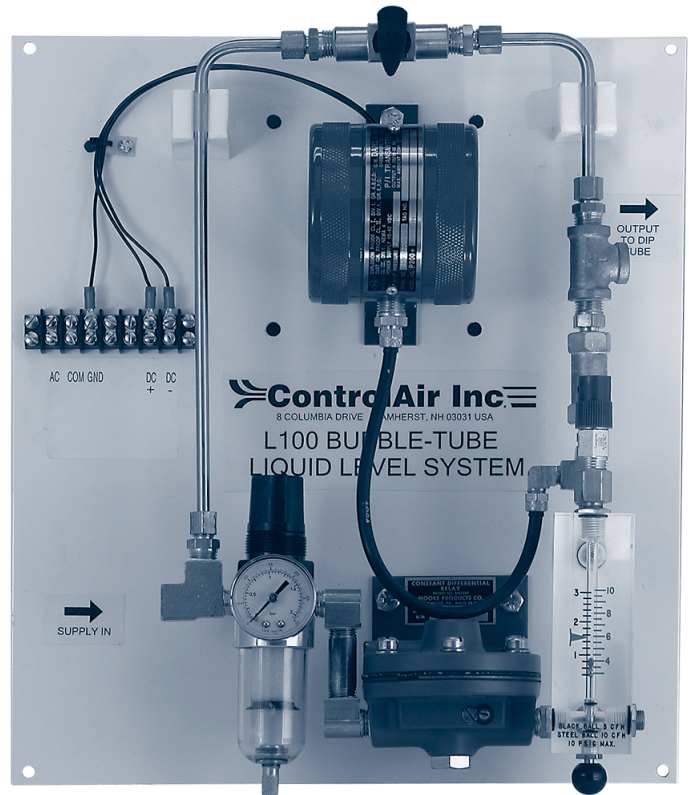

Warranty

ControlAir, Inc. products are warranted to be free from defects in materials and workmanship for a period of eighteen months from the date of sale, provided said products are used according to ControlAir, Inc. recommended usages. ControlAir, Inc.'s liability is limited to the repair, purchase price refund, or replacement in kind, at ControlAir, Inc.'s sole option, of any products proved defective. ControlAir, Inc. reserves the right to discontinue manufacture of any products or change products materials, designs or specifications without notice.