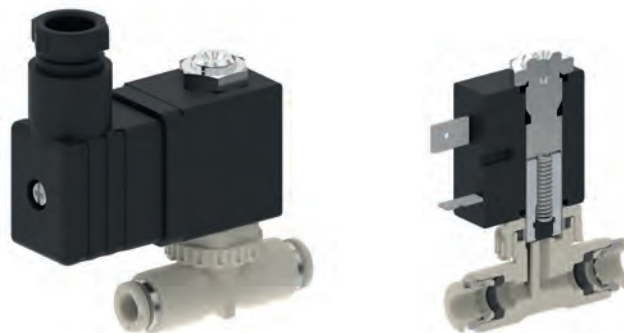

DIGMA Solenoid Valves Type EAV Series 800

Further development based on the EAV series 700.

This series of plastic valves is suitable for many aggressive medium and thanks to the use of high-quality magnetic steels, offers among other things a standard solution for controlling hot water and steam.

Another characteristic of this type of construction is the welded stainless steel plunger guide which ensures increased pressure and leakage assurance.

Solenoid coils with different performance classes enable a favourable adaptation to the diverse requirements with regard to nominal size, operating pressure, power consumption, type of voltage or permissible self-heating.

Features

- Unbeatable price-performance ratio
- Individual product developments
- Minimal heat loss
- Extremely high material strength
- NSF certified
- Flexibility in design
- Lightweight
- Compact dimensions
- Highest product quality
- Fail-safe and durable

CHARACTERISTICS
GENERAL

Constructional design	Seat valve, rubber seals			
Product name	2/2-way solenoid valve		3/2-way solenoid valve	
Actuation	electric, direct-acting			
Product type	EAV-8..-A..	EAV-8..-B..	EAV-8..-C..	EAV-8..-D..
Function	"A" normally closed (closing with flow)	"B" normally open (closing against current)	"C" normally closed with "1", "2" to "3" discharged (closing against current)	"D" in 0 position "1" to "2" open, "3" closed (closing against current)
Nominal diameter	DN 1.2 to DN 3	DN 1.2 to DN 1.8	DN 1.2 to DN 3	DN 1.2 to DN 1.8
Connection	ELSA push-in connection for tube/pipe D 4 D 6			
Ambient temperature	0 °C to +60 °C			
Medium temperature	0 °C to +130 °C			
Medium viscosity	up to approx. 20 mm ² /s			
Valve body material	PPSU			
Other inner component material	Stainless steel			
Seal material	FKM EPDM (others on request)			
Mounting method	with bracket (optional) or using rigid pipework			
Mounting position	optional, preferably upright			
Approval	NSF/ANSI 169			
PNEUMATIC - HYDRAULIC				
Nominal pressure	up to PN 16 According to Type table. The numerical value of the nominal pressure PN signifies the permitted excess operating pressure OP in bar at 60 °C ambient temperature and 60 °C medium temperature. Insofar as two values are given, the first value refers to solenoid coils with highest electrical power consumption, the second value to that with lowest power consumption.			
Pressure range	Technical vacuum up to permitted operating pressure OP. For exceptions which refer to minimum permitted operating pressure see table.			
Perm. Operating pressure (PB)	20 °C -> 16 bar; 100 °C -> 12 bar; 130 °C -> 6 bar (independent of the switching function)			
Flow rate	Kv-value and QNn-value according to Type table			
Medium	gaseous or liquid			
Response time	opening time: 7 - 20 ms closing time: 12 - 20 ms			
Solenoid coils	see solenoid coils			

2/2-Way Solenoid Valve - Type EAV Series 800

 Price group **51** "A" normally closed (closing with flow)

Plastic PPSU







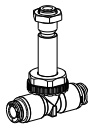

Version	DN	Kv-value water [m³/h]	Qn-value air [l/min]	For tube D	PN	Sealing material	Type	Order number	Price
 	1.2	0.04	48	6	16/12.5	FKM	EAV-813P3-A12-6FFK-00	686629	o. r.
	1.5	0.06	74	6	16/6	FKM	EAV-813P3-A15-6FFK-00	686630	o. r.
	2	0.1	115	6	16/4	FKM	EAV-813P3-A20-6FFK-00	686631	o. r.
	3	0.14	159	6	10/2	FKM	EAV-813P3-A30-6FFK-00	686632	o. r.

Illustration

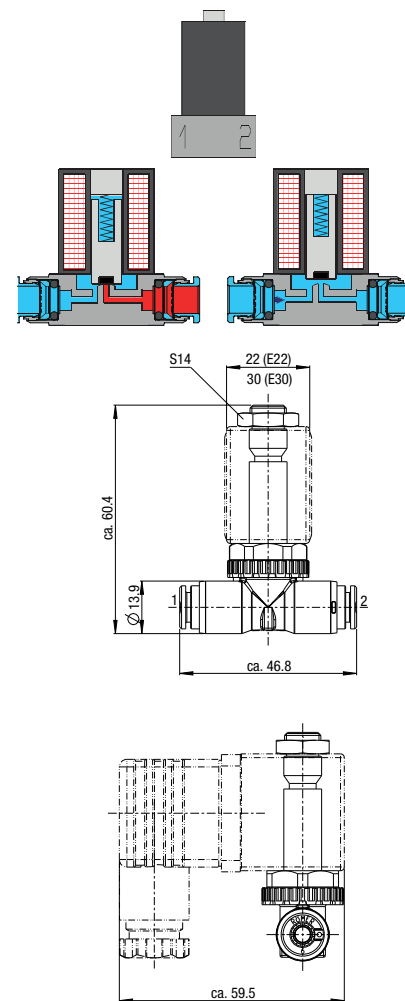
Switching pressure for 2/2-Way Solenoid Valve - Type EAV Series 800

"A" normally closed (closing with flow)

DN	Type	PN	Combinable solenoid coils			Permitted operating pressure [bar] at ambient temperature +60 °C															
			Type	Nominal power P ₂₀			AC 50 Hz  90 %U _N Medium temperature			AC 60 Hz  90 %U _N Medium temperature			DC  90 %U _N Medium temperature			DC  90 %U _N Medium temperature			DC  100 %U _N Medium temperature		
				AC 50 Hz [VA]	AC 60 Hz [VA]	DC [W]	60 °C	90 °C	130 °C	60 °C	90 °C	130 °C	60 °C	90 °C	130 °C	60 °C	90 °C	130 °C	60 °C	90 °C	130 °C
				1.2	EAV-813P3-A12..	16/12.5	E22...L.	-	-	2.5	-	-	-	-	-	-	15	10	6	8	6
			E22...M.	-	-	5	-	-	-	-	-	-	16	12	6	16	12	6	16	12	6
			E22...H.	-	-	8	-	-	-	-	-	-	16	12	6	16	12	6	16	12	6
			E28...G	-	-	6.3	-	-	-	-	-	-	16	12	6	16	12	6	16	12	6
			E30...P.	-	-	8	-	-	-	-	-	-	16	12	6	16	12	6	16	12	6
1.5	EAV-813P3-A15..	16/6	E22...L.	-	-	2.5	-	-	-	-	-	-	7	5	4	4	3	2	6	5	4
			E22...M.	-	-	5	-	-	-	-	-	-	16	12	6	12	10	6	16	12	6
			E22...H.	-	-	8	-	-	-	-	-	-	16	12	6	16	12	6	16	12	6
			E28...G	-	-	6.3	-	-	-	-	-	-	16	12	6	16	12	6	16	12	6
			E30...P.	-	-	8	-	-	-	-	-	-	16	12	6	16	12	6	16	12	6
2	EAV-813P3-A20..	16/4	E22...L.	-	-	2.5	-	-	-	-	-	-	4	3	2.5	2.5	1.5	1	3	2.5	2
			E22...M.	-	-	5	-	-	-	-	-	-	11	8	6	6	5	4.5	8	7	6
			E22...H.	-	-	8	-	-	-	-	-	-	16	12	6	10	8	6	12	10	6
			E28...G	-	-	6.3	-	-	-	-	-	-	16	12	6	13	10	6	15	12	6
			E30...P.	-	-	8	-	-	-	-	-	-	16	12	6	16	12	6	16	12	6
3	EAV-813P3-A30..	10/2	E22...L.	-	-	2.5	-	-	-	-	-	-	2	1.5	1.2	1.2	0.9	0.7	1.8	1.4	0.8
			E22...M.	-	-	5	-	-	-	-	-	-	3.5	3	2.8	2.5	2	1.5	3	2.5	2
			E22...H.	-	-	8	-	-	-	-	-	-	9	7	6	5	4	3	6	5	4
			E28...G	-	-	6.3	-	-	-	-	-	-	10	8	6	6	5	4	7	6	5
			E30...P.	-	-	8	-	-	-	-	-	-	10	9	6	9	7	6	10	9	6

2/2-Way Solenoid Valve - Type EAV Series 800
Illustration

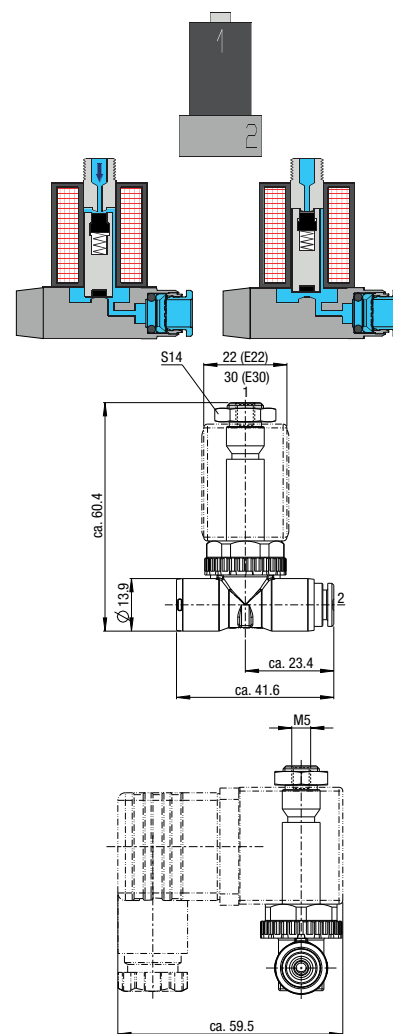
Price group	51	"B" normally open (closing against current)		Permitted operating pressure table below				Plastic PPSU	
Version	DN	Kv-value water [m³/h]	Qn-value air [l/min]	For tube D	PN	Sealing material	Type	Order number	Price
 	1.2	0.04	44	6	16	FKM	EAV-813P3-B12-6FFK-00	686633	o. r.
	1.5	0.04	51	6	10	FKM	EAV-813P3-B15-6FFK-00	686634	o. r.
	1.8	0.06	77	6	8	FKM	EAV-813P3-B18-6FFK-00	686635	o. r.

Switching pressure for 2/2-Way Solenoid Valve - Type EAV Series 800

"B" normally open (closing against current)

DN	Type	PN	Combinable solenoid coils			Permitted operating pressure [bar] at ambient temperature +60 °C																
			Type	Nominal power P ₂₀			AC 50 Hz 90 %U _N Medium temperature			AC 60 Hz 90 %U _N Medium temperature			DC 90 %U _N Medium temperature			DC 90 %U _N Medium temperature			DC 100 %U _N Medium temperature			
				AC 50 Hz [VA]	AC 60 Hz [VA]	DC [W]	60 °C	90 °C	130 °C	60 °C	90 °C	130 °C	60 °C	90 °C	130 °C	60 °C	90 °C	130 °C	60 °C	90 °C	130 °C	
1.2	EAV-813P3-B12..	16	E22...M.	-	-	5	-	-	-	-	-	-	16	12	6	16	12	6	16	12	6	
			E22...H.	-	-	8	-	-	-	-	-	-	-	16	12	6	16	12	6	16	12	6
			E28...G	-	-	6,3	-	-	-	-	-	-	-	16	12	6	16	12	6	16	12	6
			E30...P.	-	-	8	-	-	-	-	-	-	-	16	12	6	16	12	6	16	12	6
1.5	EAV-813P3-B15..	10	E22...M.	-	-	5	-	-	-	-	-	-	10	10	6	10	10	6	10	10	6	
			E22...H.	-	-	8	-	-	-	-	-	-	-	10	10	6	10	10	6	10	10	6
			E28...G	-	-	6,3	-	-	-	-	-	-	-	10	10	6	10	10	6	10	10	6
			E30...P.	-	-	8	-	-	-	-	-	-	-	10	10	6	10	10	6	10	10	6
1.8	EAV-813P3-B18..	8	E22...M.	-	-	5	-	-	-	-	-	-	8	8	6	7	7	6	8	8	6	
			E22...H.	-	-	8	-	-	-	-	-	-	-	8	8	6	8	8	6	8	8	6
			E28...G	-	-	6,3	-	-	-	-	-	-	-	8	8	6	8	8	6	8	8	6
			E30...P.	-	-	8	-	-	-	-	-	-	-	8	8	6	8	8	6	8	8	6

3/2-Way Solenoid Valve - Type EAV Series 800

Illustration

Price group **51** "C" normally closed with "1", "2" to "3" discharged (closing against current)

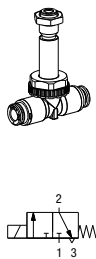

Version	DN	Kv-value Water [m³/h]	Qn-value air [l/min]	For tube D	PN	Sealing material	Type	Order number	Price
	1.2	1 > 2 0.04 2 > 3 0.06	1 > 2 44 2 > 3 72	6	12.5	FKM	EAV-813P3-C12-6FFK-00	686636	o. r.
	1.5	1 > 2 0.05 2 > 3 0.08	1 > 2 63 2 > 3 98	6	10	FKM	EAV-813P3-C15-6FFK-00	686637	o. r.
	2	1 > 2 0.08 2 > 3 0.08	1 > 2 101 2 > 3 98	6	6	FKM	EAV-813P3-C20-6FFK-00	686638	o. r.
	3	1 > 2 0.13 2 > 3 0.08	1 > 2 151 2 > 3 98	6	4	FKM	EAV-813P3-C30-6FFK-00	686639	o. r.

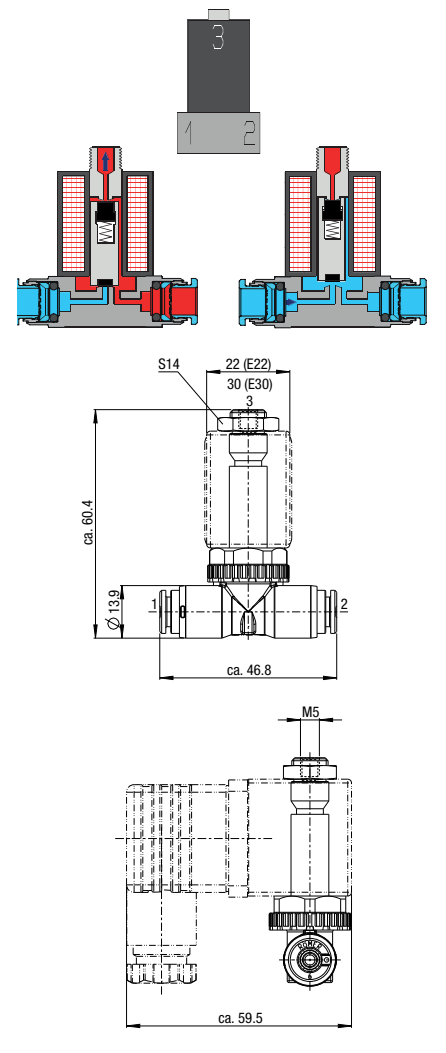

Switching pressure for 3/2-Way Solenoid Valve - Type EAV Series 800

"C" normally closed with "1", "2" to "3" discharged (closing against current)

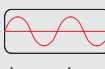
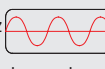
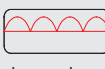
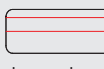
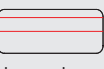
DN	Type	PN	Combinable solenoid coils			Permitted operating pressure [bar] at ambient temperature +60 °C																			
			Type	Nominal power P ₂₀			AC 50 Hz  90 %U _N Medium temperature			AC 60 Hz  90 %U _N Medium temperature			DC  90 %U _N Medium temperature			DC  90 %U _N Medium temperature			DC  100 %U _N Medium temperature						
				AC 50 Hz [VA]	AC 60 Hz [VA]	DC [W]	60 °C	90 °C	130 °C	60 °C	90 °C	130 °C	60 °C	90 °C	130 °C	60 °C	90 °C	130 °C	60 °C	90 °C	130 °C				
1.2	EAV-813P3-C12..	12.5	E22...M.	-	-	5	-	-	-	-	-	-	12.5	12	6	12.5	12	6	12.5	12	6				
			E22...H.	-	-	8	-	-	-	-	-	-	-	-	12.5	12	6	12.5	12	6	12.5	12	6		
			E28...G	-	-	6.3	-	-	-	-	-	-	-	-	12.5	12	6	12.5	12	6	12.5	12	6		
			E30...P.	-	-	8	-	-	-	-	-	-	-	-	12.5	12	6	12.5	12	6	12.5	12	6		
1.5	EAV-813P3-C15..	10	E22...M.	-	-	5	-	-	-	-	-	-	10	10	6	10	10	6	10	10	6				
			E22...H.	-	-	8	-	-	-	-	-	-	-	-	10	10	6	10	10	6	10	10	6		
			E28...G	-	-	6.3	-	-	-	-	-	-	-	-	10	10	6	10	10	6	10	10	6		
			E30...P.	-	-	8	-	-	-	-	-	-	-	-	10	10	6	10	10	6	10	10	6		
2.0	EAV-813P3-C20..	6	E22...M.	-	-	5	-	-	-	-	-	-	6	6	6	6	6	6	6	6	6	6			
			E22...H.	-	-	8	-	-	-	-	-	-	-	-	6	6	6	6	6	6	6	6	6		
			E28...G	-	-	6.3	-	-	-	-	-	-	-	-	6	6	6	6	6	6	6	6	6	6	
			E30...P.	-	-	8	-	-	-	-	-	-	-	-	6	6	6	6	6	6	6	6	6	6	
3.0	EAV-813P3-C30..	4	E22...M.	-	-	5	-	-	-	-	-	-	4	4	4	4	4	4	4	4	4	4			
			E22...H.	-	-	8	-	-	-	-	-	-	-	-	4	4	4	4	4	4	4	4	4	4	
			E28...G	-	-	6.3	-	-	-	-	-	-	-	-	4	4	4	4	4	4	4	4	4	4	4
			E30...P.	-	-	8	-	-	-	-	-	-	-	-	4	4	4	4	4	4	4	4	4	4	4

3/2-Way Solenoid Valve Type EAV Series 800
Illustration

Price group	51	"D" in 0 position "1" to "2" open, "3" closed (closing against current)		Permitted operating pressure Table below			Plastic PPSU		
Version	DN	Kv-value water [m³/h]	QNm-value air [l/min]	For tube D	PN	Sealing material	Type	Order number	Price
	1.2	1 > 2 0.04 2 > 3 0.04	1 > 2 44 2 > 3 48	6	16	FKM	EAV-813P3-D12-6FFK-00	686640	o. r.
	1.5	1 > 2 0.04 2 > 3 0.06	1 > 2 51 2 > 3 74	6	10	FKM	EAV-813P3-D15-6FFK-00	686641	o. r.
	1.8	1 > 2 0.06 2 > 3 0.1	1 > 2 77 2 > 3 115	6	8	FKM	EAV-813P3-D18-6FFK-00	686642	o. r.

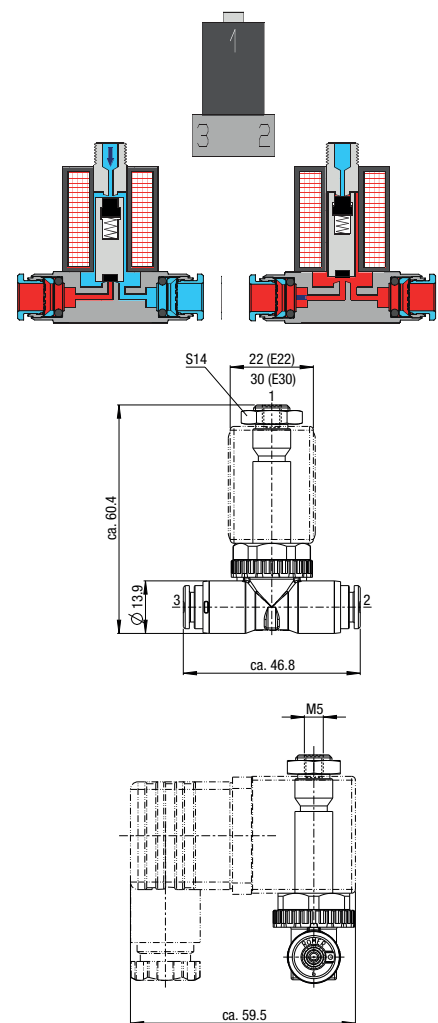
Switching pressure for 3/2-Way Solenoid Valve - Type EAV Series 800

"D" in 0 position "1" to "2" open, "3" closed (closing against current)

DN	Type	PN	Combinable solenoid coils			Permitted operating pressure [bar] at ambient temperature +60 °C																
			Type	Nominal power P ₂₀		AC 50 Hz			AC 60 Hz			DC			DC			DC				
				AC 50 Hz [VA]	AC 60 Hz [VA]	DC [W]	90 %U _N Medium temperature			90 %U _N Medium temperature			90 %U _N Medium temperature			90 %U _N Medium temperature			100 %U _N Medium temperature			
				60 °C	90 °C	130 °C	60 °C	90 °C	130 °C	60 °C	90 °C	130 °C	60 °C	90 °C	130 °C	60 °C	90 °C	130 °C	60 °C	90 °C	130 °C	
1.2	EAV-813P3-D12..	16	E22...M.	-	-	5	-	-	-	-	-	-	16	12	6	16	12	6	16	12	6	
			E22...H.	-	-	8	-	-	-	-	-	-	-	16	12	6	16	12	6	16	12	6
			E28...G	-	-	6.3	-	-	-	-	-	-	-	16	12	6	16	12	6	16	12	6
			E30...P.	-	-	8	-	-	-	-	-	-	-	16	12	6	16	12	6	16	12	6
1.5	EAV-813P3-D15..	10	E22...M.	-	-	5	-	-	-	-	-	-	10	10	6	10	10	6	10	10	6	
			E22...H.	-	-	8	-	-	-	-	-	-	-	10	10	6	10	10	6	10	10	6
			E28...G	-	-	6.3	-	-	-	-	-	-	-	10	10	6	10	10	6	10	10	6
			E30...P.	-	-	8	-	-	-	-	-	-	-	10	10	6	10	10	6	10	10	6
1.8	EAV-813P3-D18..	8	E22...M.	-	-	5	-	-	-	-	-	-	8	8	6	7	7	6	8	8	6	
			E22...H.	-	-	8	-	-	-	-	-	-	-	8	8	6	8	8	6	8	8	6
			E28...G	-	-	6.3	-	-	-	-	-	-	-	8	8	6	8	8	6	8	8	6
			E30...P.	-	-	8	-	-	-	-	-	-	-	8	8	6	8	8	6	8	8	6